

LITTER BIN: A MUST FOR CLEAN TOWNS EVERYWHERE



EASY HANDLING
STURDY CONSTRUCTION
EYE-CATCHING

Assembly

- Easy to assemble
- Option for either wall or post-mounting



Emptying

- Handle and grip cavity at the base for quick and easy emptying
- Triangular lock for extra security



Protection hood

- Hood for protection from wind and rain
- Prevents depositing of bulky household or commercial waste



LITTER BIN

Material

- **Polymer components:**
 - Resistant to decay, frost, heat and chemicals
 - Special UV-stabilisation provides excellent ageing characteristics
- **Corrosion resistant metal components:**
 - Galvanised mounting bracket
 - Stainless steel plate for extinguishing cigarettes
- **Long service life:**
 - High quality materials
 - Most advanced manufacturing processes
 - Withstands exposure to high mechanical stress levels
- **Recycling:**
 - All container parts are recyclable

Advantages

- Complies fully with quality requirements of DIN 30713 standard
- Easy to assemble
- Can be mounted on walls or posts
- Smooth surface makes cleaning easy
- Easy and hygienic emptying
- Metal sheet on the rim protects from cigarette damage
- Stackable
- Economical volume of 50 litres
- Eye-catching

Imprints and markings

- Manufacturer, year of manufacture, material
- "Tidyman" symbol (see picture on front page)
- Individual markings with imprints, hot-foil printing or adhesive labels are available on request

Dimensions - Weights - Standards

- Nominal volume: 50 litres
- Net weight: 5 kg
- Permitted total weight: 25 kg

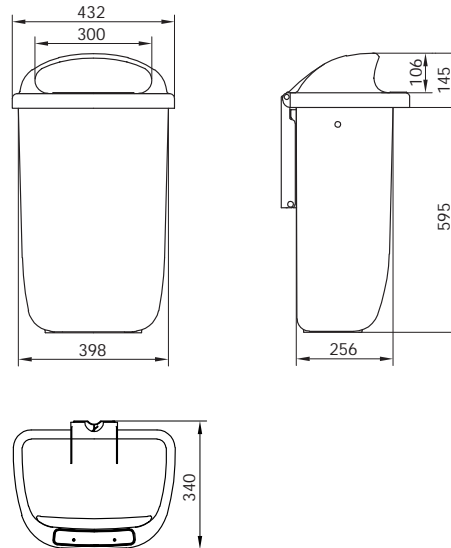

all dimensions according to DIN 30713

Colours

- Standard colours: orange (RAL 2011), green (RAL 6017)
- Special colours are available on request
- All additives are cadmium free and environmentally friendly



SULO

Sulo MGB Australia Pty Ltd
123 Wisemans Ferry Road
Somersby NSW 2250
AUSTRALIA
Telephone: +61 (0) 2 - 4348 8188
Facsimile: +61 (0) 2 - 4348 8128
Internet: www.sulo.com.au
E-mail: info@sulo.com.au

Sulo – Queensland Office
11 Argon Street
Sumner Park QLD 4070
AUSTRALIA
Telephone: +61 (0) 7 - 3725 5000
Facsimile: +61 (0) 7 - 3725 5099

Sulo – Victorian Office
6 Capital Link Drive
Campbellfield VIC 3061
AUSTRALIA
Telephone: +61 (0) 3 - 9357 7320
Facsimile: +61 (0) 3 - 9357 7340